



***HELI ENGINEERING cc***

Reg. No. 2000/004633/23

***METAL FORMING MACHINE SPECIALISTS***

**PRESS BRAKE TOOLING**



STANDARD MALE DIES

10.10/90°	10.10/88°	10.11/45°	10.12/35°	10.13/35°
10.14/90°	10.14/88°	10.15/90°	10.15/88°	10.16/90°
10.17/35°	10.05	40.02	40.09	Dies are available in sectionalised sets as illustrated below

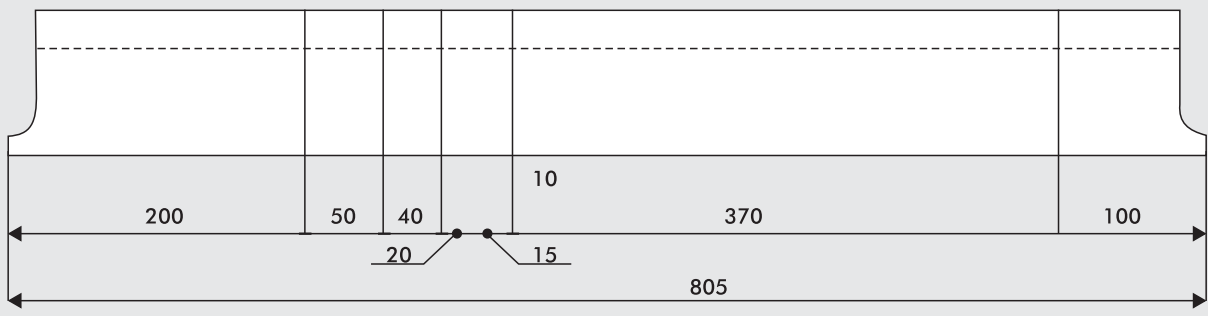

STANDARD SECTIONING LENGTHS FOR MALE DIES.  
Special sectioning lengths can be supplied on request.

**Our dies are made from high steel quality hardened by induction on working parts at 50-60 HRC and then ground with the highest accuracy. We guarantee a perfect matching.**

STANDARD FEMALE DIES

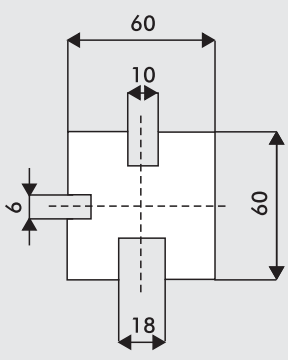
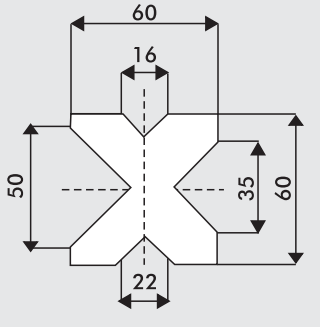
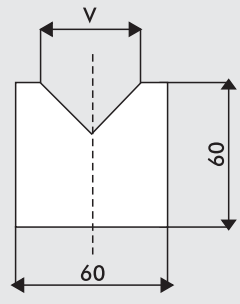
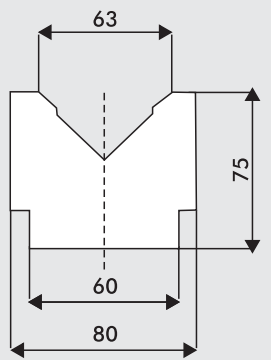
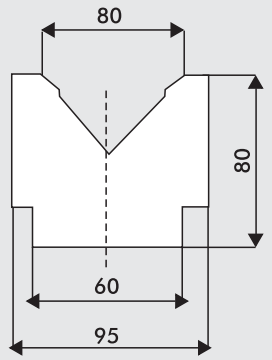
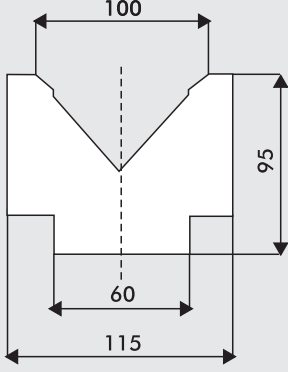
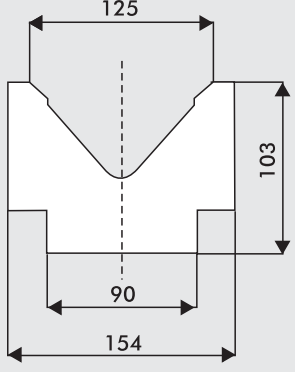
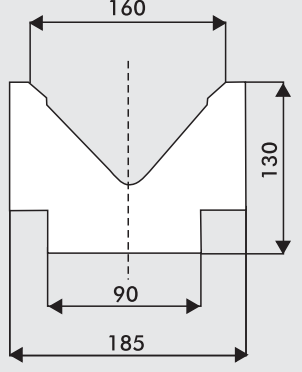
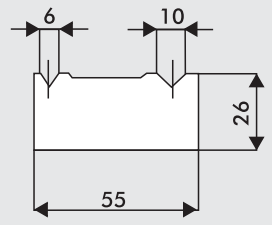
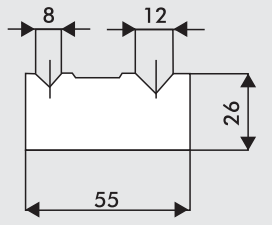
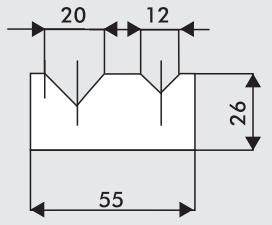
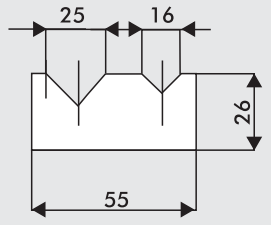
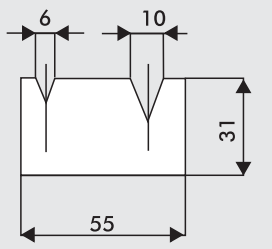
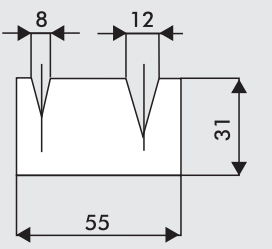
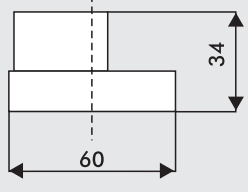
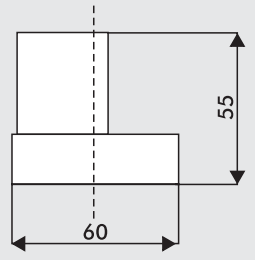
<p>20.08</p> 	<p>20.09</p>  <p>V 16-22=88° V 35-50=85°</p>	<p>20.11/32/40/50</p>  <p>V = 85° V = 32-40-50</p>	<p>20.11/63</p>  <p>V = 85°</p>
<p>20.11/80</p>  <p>V=85°</p>	<p>20.11/100</p>  <p>V=85°</p>	<p>20.11/125</p>  <p>V=85°</p>	<p>20.11/160</p>  <p>V=85°</p>
<p>20.12/90°</p>  <p>V=90°</p>	<p>20.13/90°</p>  <p>V=90°</p>	<p>20.14/88°</p>  <p>V=88°</p>	<p>20.15/88°</p>  <p>V=88°</p>
<p>20.12/35°</p>  <p>V=35°</p>	<p>20.12/35°</p>  <p>V=35°</p>	<p>40.06</p> 	<p>40.07.55</p> 

Our standard bending dies are always available in our stock in lengths of mms.: 415, 835 and sectioned. Each bending die is checked very carefully in order to guarantee its QUALITY, PRECISION AND INTERCHANGEABILITY.

STANDARD OFFSET DIES AND UNITS

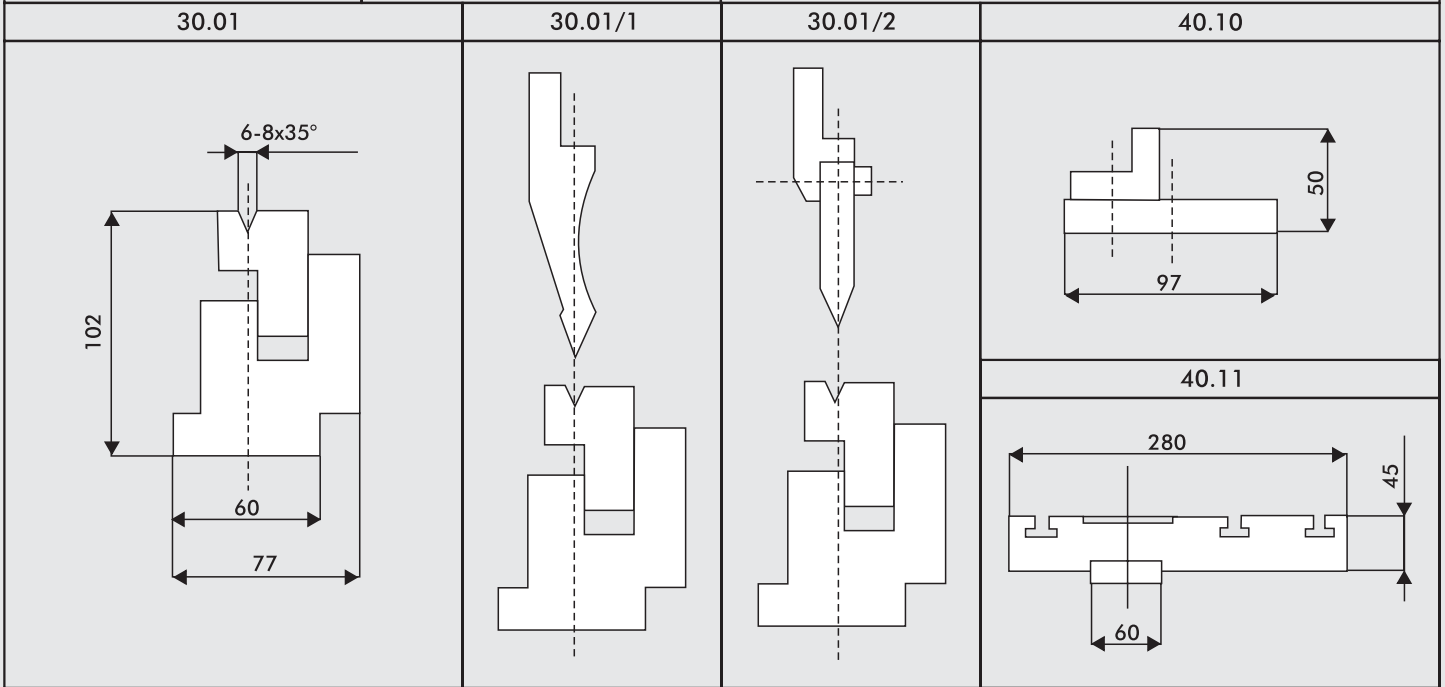
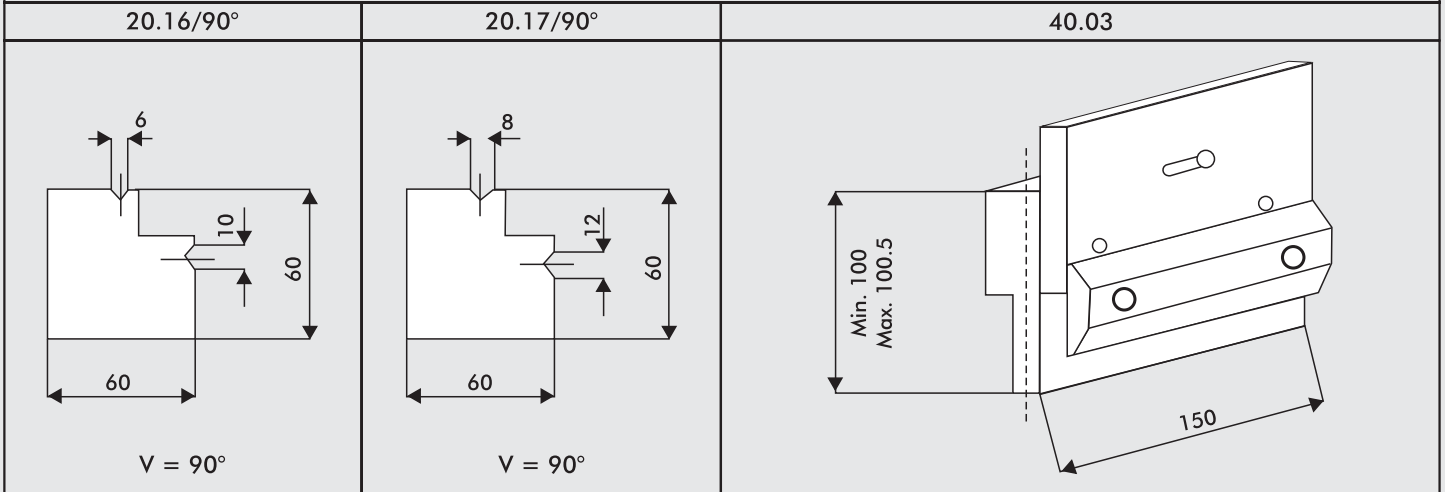

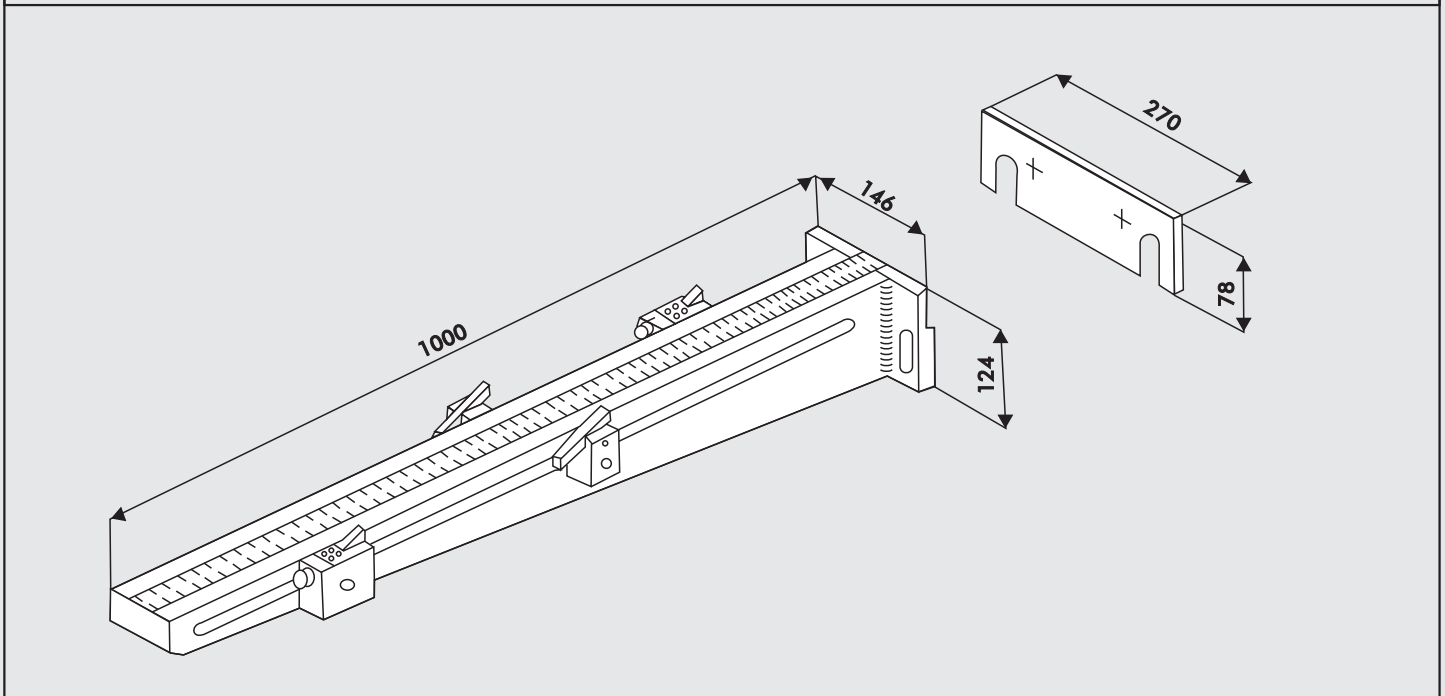

40.00 Standard stop guage mod. PR for press-brakes

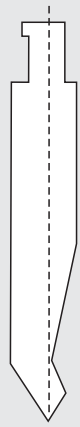
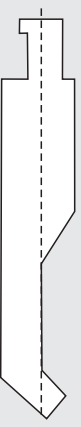

On request we study and produce special units  
 Our production is executed by means of high  
 technology machines.

STANDARD FEMALE DIES

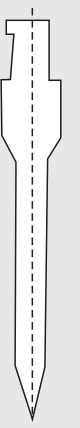
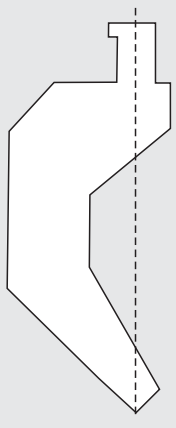
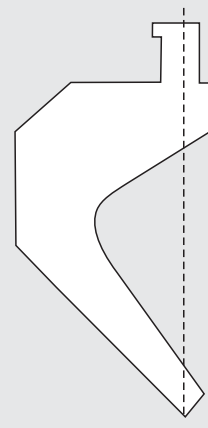
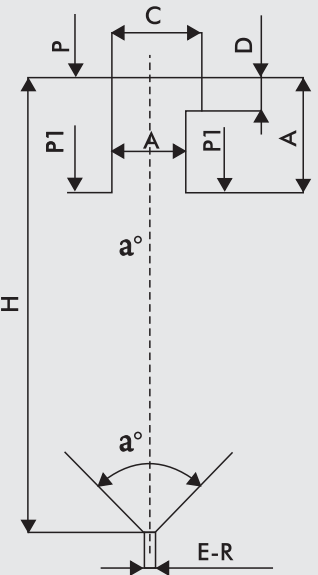
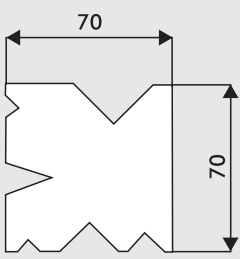
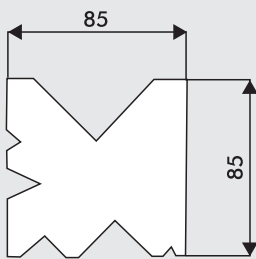
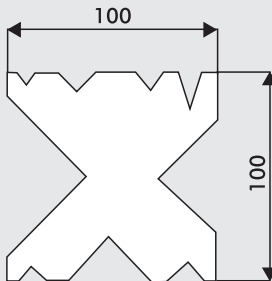
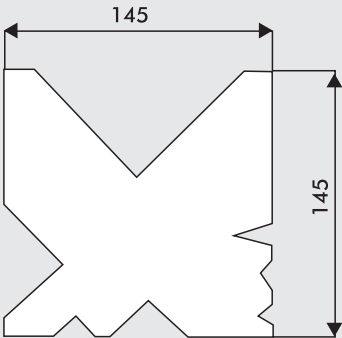
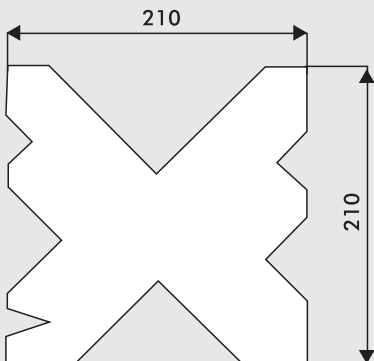
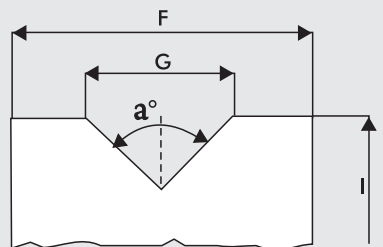
<p>10.01</p> 	<p>10.02</p> 	<p>10.03</p> 	<p>10.04</p> 
<p>10.05</p> 	<p>10.07</p> 	<p>10.08</p> 	 <p>For any enquiry on special; male dies, please state:</p> <ul style="list-style-type: none"> <li>- total height H</li> <li>- dimensions of tongue</li> <li>- degrees on the nose <math>a^\circ</math></li> <li>- measure of flat on E or radius</li> <li>- whether the press-brake presses on P or P1</li> <li>- length</li> </ul>
<p>20.18</p> 	<p>20.19</p> 	<p>20.21</p> 	
<p>20.24</p> 	<p>20.26</p> 	 <p>For any enquiry on special; female dies please state:</p> <ul style="list-style-type: none"> <li>-length</li> <li>-dimensions FxH</li> <li>-number and position of grooves</li> <li>-width of grooves G</li> <li>-degrees on grooves <math>a^\circ</math></li> </ul>	

**Our factory produces standard and special dies for any make of press-brake up to a maximum length of 8000 mms. in one piece. These bending could be hardened by induction on working parts at 50-60 HRC and then ground, or from steel with resistance up to 120kg/mm milled, or milled and ground.**

SPECIAL OFFSET DIES

30.03

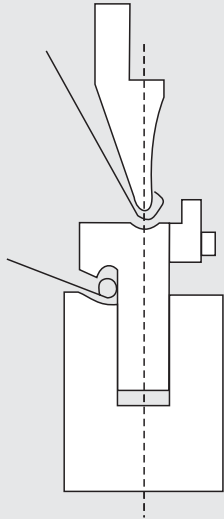

30.04

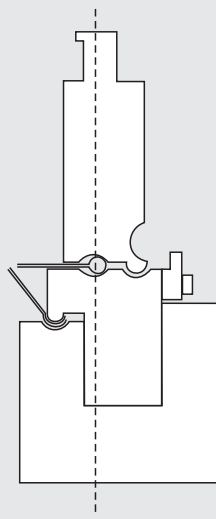

30.05

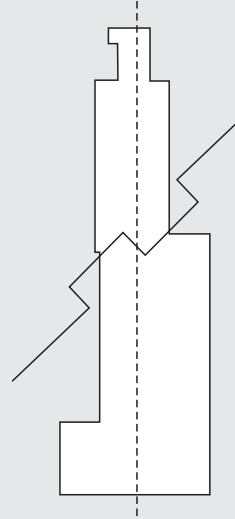

30.06

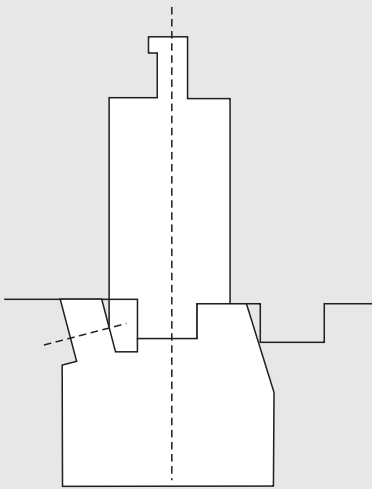

30.10

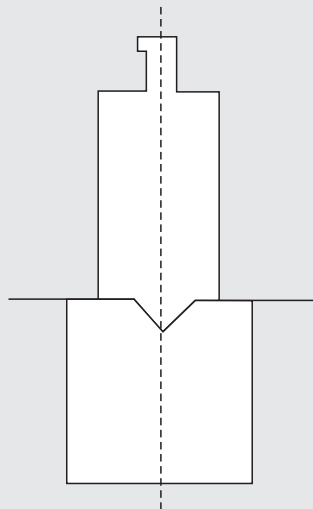

30.11

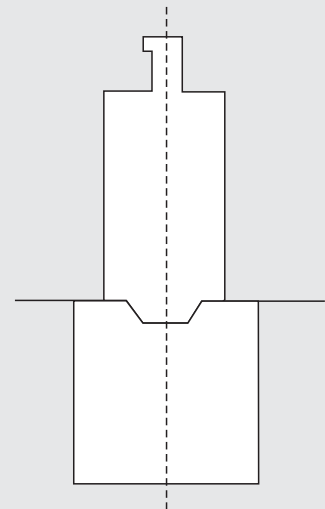

For any enquiry on special offset dies, please state:  
 type of press-brake and its features (mechanical or hydraulic, tonnage, length, maximum distance between table and ram, stroke and adjustment);  
 type, thickness and length of material to be formed;  
 sketch of profiles to be formed and indication of bends to be obtained in one stroke

Each special offset die is tested in our factory.  
 For any of your bending problems, please call us!  
 Our technical office is at your disposal in order to give you a practical and pure solution.



**HELI ENGINEERING cc**

Reg. No. 2000/004633/23

**METAL FORMING MACHINE SPECIALISTS**

MANUFACTURERS OF HYDRAULIC PRESSBRAKES-GUILLOTINES-PLATE ROLLS, SPECIAL PURPOSE MACHINES

**“FROM THE PAST INTO THE FUTURE”**

**FACTORY & HEAD OFFICE:**  
 2 PATRICK ROAD, JET PARK 1459  
 SOUTH AFRICA

PO BOX 30434  
 JET PARK 1469  
 SOUTH AFRICA

TEL: (011) 397-3650/1/2/3/4

FAX: (011) 397-3101

E-mail: sales@heli-engineering.co.za